

BASIC BUCKET

FULLY AUTOMATIC LABELLING MACHINE

The Basic Bucket offers small to medium scale packaging operations with unparalleled flexibility to handle a wide range of buckets and large containers with wrap around label types.



MACHINE FEATURES



- Easy to operate integrated control system with label counter and pre-set batch controls.
- Suitable for a wide range of large format cylindrical labelling applications.
- Easy to operate integrated control system with keypad and digital display.
- Stepper motor drive for fast and accurate labelling.
- Opaque label detection as standard.
- Pneumatically operated gating and bucket lift with motorised drive assembly for optimum label placement.
- Easily adjustable label pre-dispensing and label positioning with graduated scale.
- Optional full IQ/OQ Validation support package.
- Hygienic design using FDA approved materials.
- Small machine footprint.

YOUR PARTNER IN PACKAGING

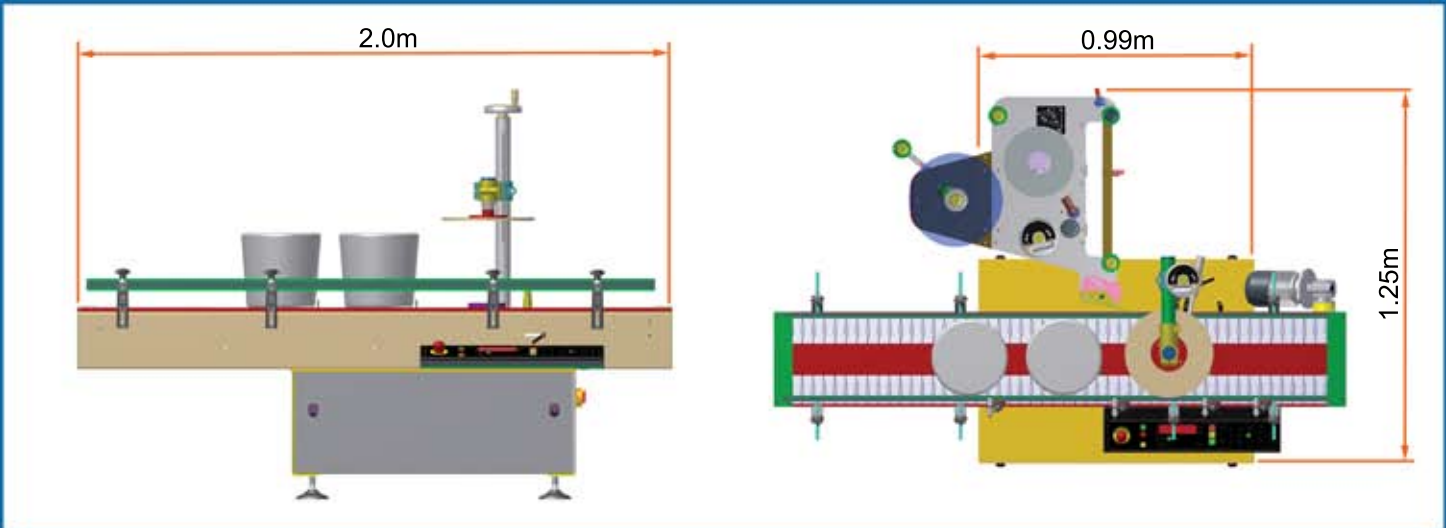

TECHNICAL SPECIFICATION

Dispensing Speed:	Up to 15 metres per minute.
Spool Diameter:	46mm or 76mm
Maximum Label Size:	300mm x 125mm wide
Control System:	Integrated PLC
Drive System:	Stepper Motor
Build Standard:	cGMP, CE marked in accordance with Machinery Directive 2006/42/EC
Power Requirements:	220/240v 50Hz 1Phase
Pneumatic Requirement:	4 bar filtered and dried
Nett Weight:	200Kg

OPERATION

The BASIC BUCKET is operated using a simple keypad interface with digital display. Once the machine has been adjusted for the required product, buckets are fed onto the infeed of the conveyor system. A set of gates control the separation of the buckets to a predetermined pitch and as each bucket passes a sensor the bucket is momentarily stopped and lifted on a rotating platform.

Once the bucket has been lifted and is concentrically located the platform rotates allowing a label to be dispensed and applied. After label application the bucket lowers and is then fed out.