



TESTE DI GHIERATURA E CHIUSURA

Via Kennedy, 9/G
20090 Rodano Millepini
Milano - Italia

www.beca-closures.com

info@beca-closures.com



TM SERIES

Via Kennedy, 9/G
20090 Rodano Millepini
Milano - Italia

Www.beca-closures.com



Teste di ghiratura e bordatura per tappi in alluminio per macchine riempitrici e tappatrici di ogni genere e velocità.



Ferruling and curling head for aluminium caps for filling and capping machine



Série de vissage, sertissage et operculage pour bouchons en plastique et aluminium sur machines remplisseuses, boucheuses de chaque genre et vitesse.

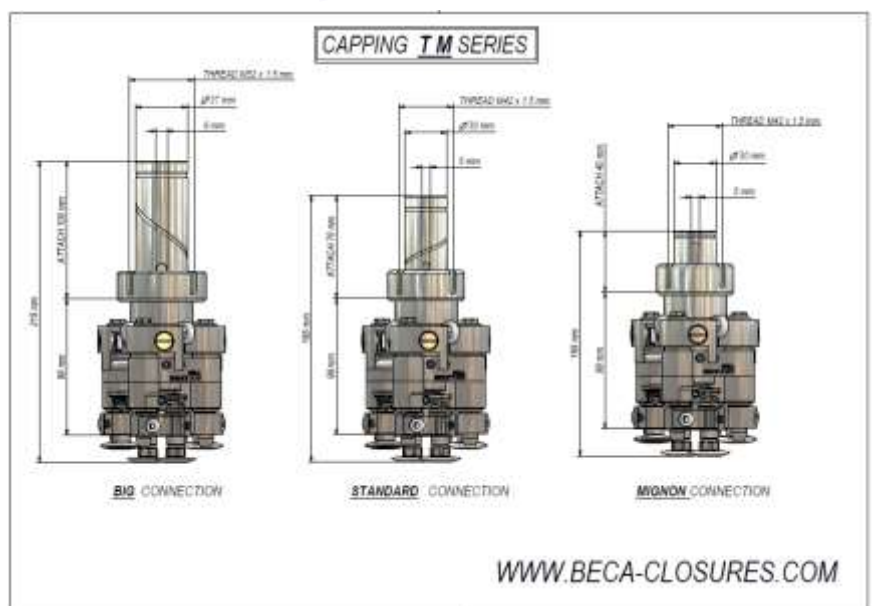



TM SERIES

Via Kennedy, 9/G
20090 Rodano Millepini
Milano - Italia

[Www.beca-closures.com](http://www.beca-closures.com)



Teste di ghieratura e bordatura per tappi in alluminio per macchine riempitrici e tappatrici di ogni genere e velocità.



Ferruling and curling head for aluminium caps for filling and capping machine



Série de vissage, sertissage et operculage pour bouchons en plastique et aluminium sur machines remplisseuses, boucheuses de chaque genre et vitesse.

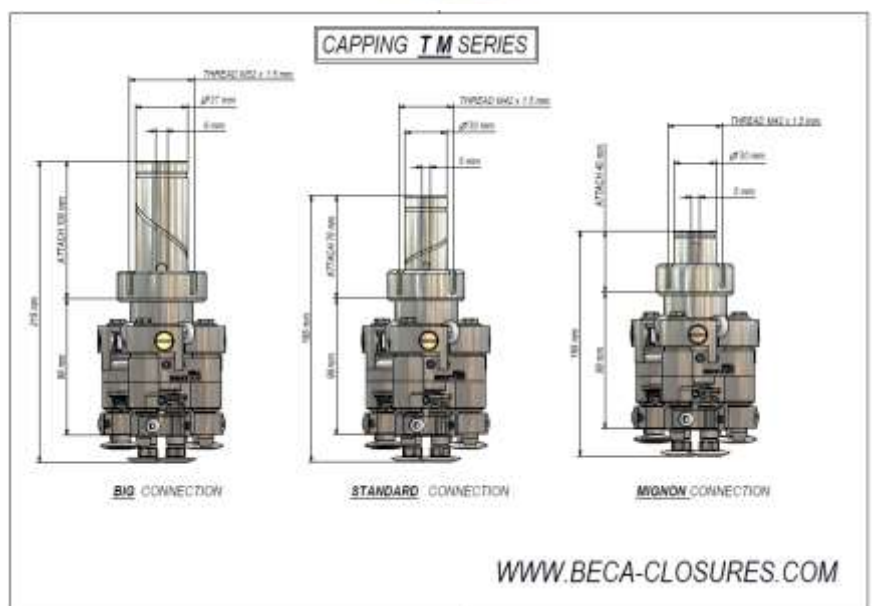



GB SERIES

Via Kennedy, 9/G
20090 Rodano Millepini
Milano - Italia

Www.beca-closures.com



Teste di ghiera e bordatura per tappi in alluminio per macchine riempitrici e tappatrici di ogni genere e velocità.



Ferruling and curling head for aluminium caps for filling and capping machine



Série de vissage, sertissage et operculage pour bouchons en plastique et aluminium sur machines remplisseuses, boucheuses de chaque genre et vitesse.





GB SERIES

THREE FINGERS

Via Kennedy, 9/G
20090 Rodano Millepini
Milano - Italia

[Www.beca-closures.com](http://www.beca-closures.com)



Teste di ghiera e bordatura per tappi in alluminio per macchine riempitrici e tappatrici di ogni genere e velocità.



Ferruling and curling head for aluminium caps for filling and capping machine



Série de vissage, sertissage et operculage pour bouchons en plastique et aluminium sur machines rempisseuses, boucheuses de chaque genre et vitesse.



info@beca-closures.com

DATI TECNICI

Serie di avvitamento, ghieratura e bordatura per tappi in plastica ed alluminio su macchine riempitrici, tappatrici di ogni genere e velocità:

GBA: Testa di avvitamento con premibocca.

TM2: Testa di chiusura con due rulli di bordatura.

TM3: Testa di chiusura con tre rulli di bordatura.

TM4: Testa di chiusura con due rulli bordatori e due filettatori per capsule PFP.

Disponibile:

- Per tappi in alluminio
- Per tappi in alluminio con mantello lungo
- Per ghiera con e senza gommino
- Con attacchi a richiesta a seconda della macchina

TECHNICAL DATA

Screw, Ferruling and curling head for plastic and aluminium caps available with filling and capping machines:

GBA: Screwer Head with stuffing

TM2: Closed head with two edging roller bushes

TM3: Closed Head with three edging roller bushes

TM4: Closed Head with two edging roller bushes and two threading roller arm for caps.

Available:

- For aluminium caps
- For aluminium caps with long cover
- For ferrules with and without rubber
- With attaches if required that change for machines

DONNEES TECHNIQUES

Série de vissage, sertissage et operculage pour bouchons en plastique et aluminium sur machines remplisseuses, boucheuses de chaque genre et vitesse.

GBA: Tete de vissage avec appui douille

TM2: Tete de fermeture avec deux rouleaux de sertissage

TM3: Tete de fermeture avec trois rouleaux de sertissage

TM4: Tete de fermeture avec deux rouleaux de sertissage et deux empreintes pour capsules PFP

Disponible:

- Pour bouchon en aluminium
- Pour bouchon en aluminium avec ... long
- Pour embouts avec et sans gomme
- Avec attaches sur demande selon la machine

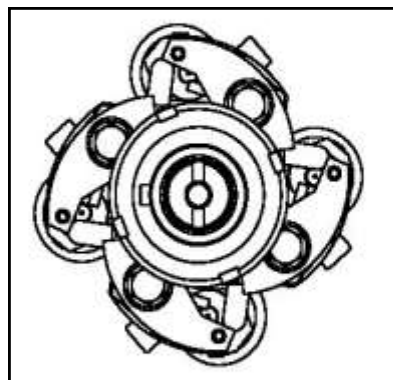
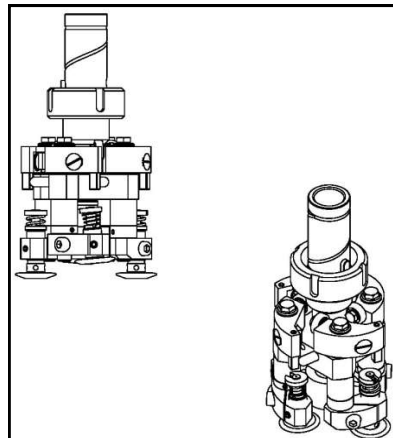

Distributed By:



www.kbw-packaging.com



Eventuali modifiche a miglioramento della macchina potranno essere apportate senza preavviso da parte del costruttore.