

# AC 2000 AUTO

## FULLY AUTOMATIC TABLET COUNTING MACHINE

The AC 2000 Auto offers small to medium scale counting operations with an unparalleled flexibility over a wide range of tablet types.



## MACHINE FEATURES

- 4.6" vertical touch screen capable of storing up to 50 recipes
- Counts coated and uncoated tablets, hard and soft gelatine capsules and dragees.
- Accurate dispensing with excellent repeatability
- Simple operation with fast product change over
- Tool free removable product contact parts
- Motorised head lift
- Integrated fault / alarms
- Option to add unscrambling and accumulation tables
- Dust extraction point
- Constructed in compliance with FDA approved materials
- Optional full IQ/OQ Validation support documentation
- Small machine footprint

# YOUR PARTNER IN PACKAGING

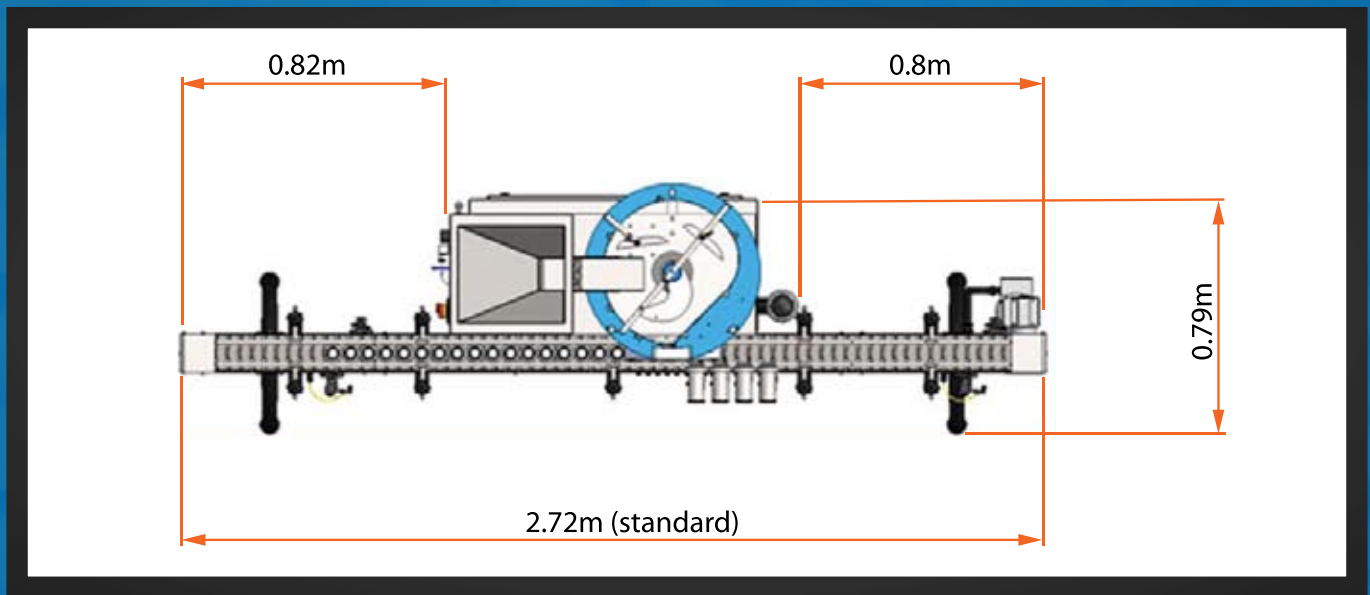

## TECHNICAL SPECIFICATION

Output:	30 bottles per minute based on a 50 count Ø5mm round tablet
Electrical Control System:	Omron
Pneumatic Control System:	Festo
Electrical Requirements:	220/240v 50 Hz 1 Ph or 110/120v 60 Hz
Pneumatic Requirements:	4 – 7 Bar, Filtered and dried
Build Standard:	cGMP, CE marked in accordance with Machinery Directive 2006/42/EC
Product size:	Tablet Ø5mm - Ø15mm. Capsule #5 - #00
Container size:	Diameter – Ø20mm to Ø110mm, Height – 30mm to 200mm
Nett weight:	288Kg

## OPERATION

Tablets or capsules are loaded into a product hopper which progressively feeds them into a vibratory feeder tray. Tablets then drop onto a rotating glass disc where a set of deflectors pre orientate the product into a single stream. The products proceed to pass through a counting sensor where they are diverted in to one of the pre positioned containers.

Containers are presented under the funnels using a conveyer system with gating. When the count target is reached the divider flap switches position and redirects the product into the next container waiting on the conveyer below.